

Flat Pattern view
SCALE: 1:2

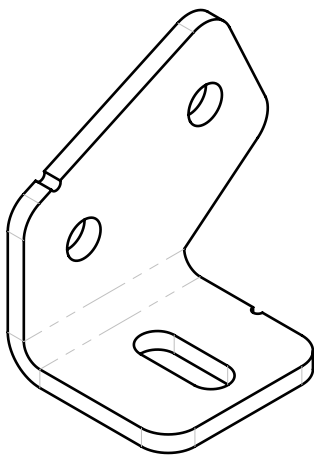
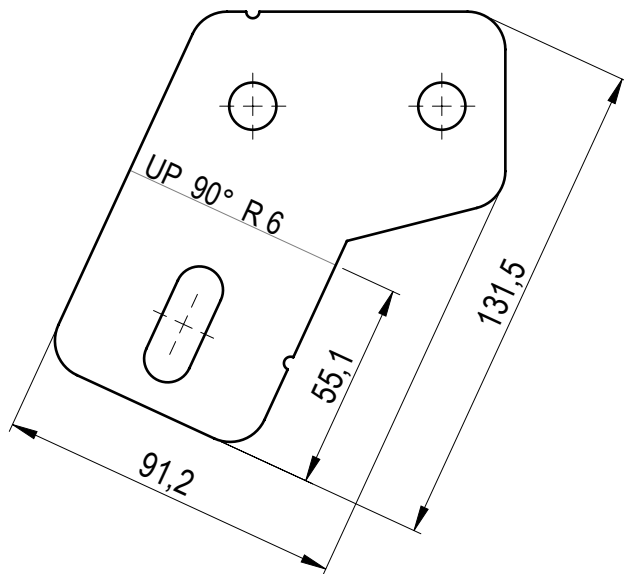
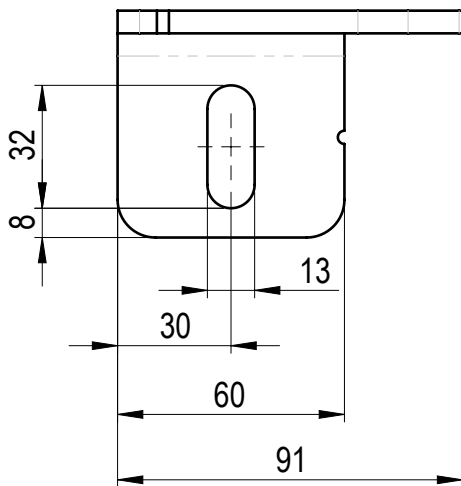

Other dimensions from .DXF file.

SHEET METAL INFORMATION	
Length, mm	131.5
Width, mm	91.2
Thickness, mm	6
Inside Bend Radius, mm	6
K-Factor	0.5
No. of Bends	1

	MATERIAL	S355J2	WEIGHT	0.359 Kg	DEBURR AND BREAK SHARP EDGES	REVISION	DATE	
	SURFACE PROTECTION	HDG EN ISO 1461	MACHINING	ISO 2768 mK	DO NOT SCALE DRAWING		28.05.2025	
	NAME	SIGNATURE	PART NO.	105-09100-05			SCALE	FORMAT
Designed by	D. Dislers						1:2	A4
Drawn by	D. Dislers		DESCRIPTION	Left bracket 1U				
Technical ref.							SHEET 1/1	